

flexiLIFT

I.C. FORKLIFT TRUCKS



6 – 10 TON

Heavy-duty machines For heavy-duty jobs.

Flexilift Group maintains close partnership with Tailift Group.

With over 30 years of manufacturing experience in forklift trucks, Tailift specifically designed for heavy lifting applications. The 6-10 ton trucks in the Tailift professional line include all the safety and efficiency features we're known for.





Operation

Your new Flexilift forklift is loaded with features **Safety** **Comfort** **Efficiency**

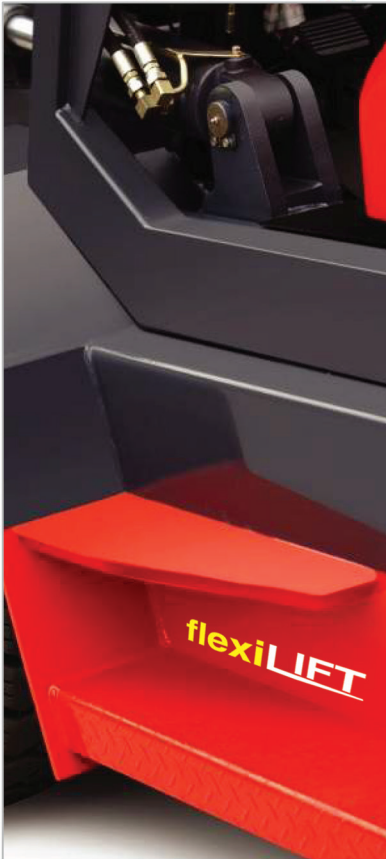

Easy entry and exit

A low floor height and non-slip steel steps provide a safe entry and exit from the cab.



Tiltable steering column

The steering column can be adjusted to accommodate any size operator in comfort.



Hydraulic steering system

The hydraulic systems delivers light steering, quick and accurate response and a small turning radius.



Mast lock system (optional)

The mast lock system automatically locks all lifting and tilting functions when the operator leaves the seat.



Electronic accelerator pedal

Offering controllable engine speed and quick response.



Deluxe suspension seat (optional)

The Grammer suspension seat allow greater range of tilting and fore/aft adjustment as well as weight adjustment to accommodate all size operators.

High visibility head guard

Excellent visibility is maintained through the heavy-duty safety cage.



1 Mini lever (optional)

The lifting and tilting function integrated in the mini lever enables a quick direction and operation. This guarantees fast manoeuvrable operation.

2 Electronic forward/reverse lever (optional)

The forward/reverse lever offer easy accessible fingertip control. It is easy to reach and also for fast and easy directional changes. Using the electric solenoid to control F/R also improved flexibility of operation.

Standard Equipment



Stable double front wheel



Wide angle rearview mirror



Exhaust pipe, upward

More powerful, more durable

OKAMURA TRANSMISSION

The Okamura transmission was developed specifically for forklifts and other types of industrial vehicles. By reversing the direction of the stator it effectively doubles the torque and delivers driving speed in low gear that would typically be produced in 2nd gear.



ADVANTAGES:

1. Smoother driving with lever shifts.
2. Greatly increased torque ratio.
3. Much less wear on the shifting components, improving performance, durability and cost-effectiveness.

PERKINS 1106D ENGINE

The six-cylinder Perkins 1106D has almost 30% more horsepower than other engines in its class. It incorporates a high pressure common rail fuel system, multi-port fuel injection and oil injection pressure of 23000psi to deliver higher efficiency than previous generations of engines. The exhaust system adheres to EU stage III and US EPA Tier III environmental exhaust standard while improving engine noise by 3-5% over previous versions and improving fuel consumption. The ECU electronic control system is completely digital with engine self-diagnosis and protection features built in.

1106D	
Horsepower	117kWm@220 rpm
Max torque	683NM@1400 rpm
Displacement	6.6 Litres
Fuel system	HEUI (Common Rail)
Speed adjustment system	ECM
Certificate	EU STAGE III US EPA TIER III

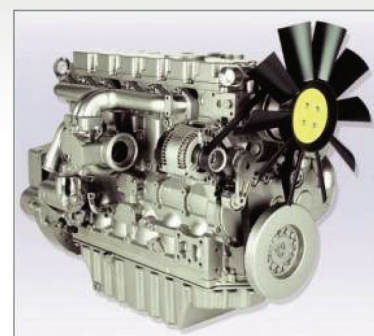

FLEXILIFT'S COMMITMENT AND VISION

- To provide the toughest and most reliable forklift trucks for even the most challenging applications.
- To provide on-time Australia-wide sales, services and spare parts support.
- Flexilift now continues close cooperation with Tailift Group, one of the top 16 world-wide forklift manufacturers.
- To partner our clients in order to intimately deliver a low-cost reliable material handling solution.
- To provide the highest level of quality and deliver the best value for money material handling solutions.

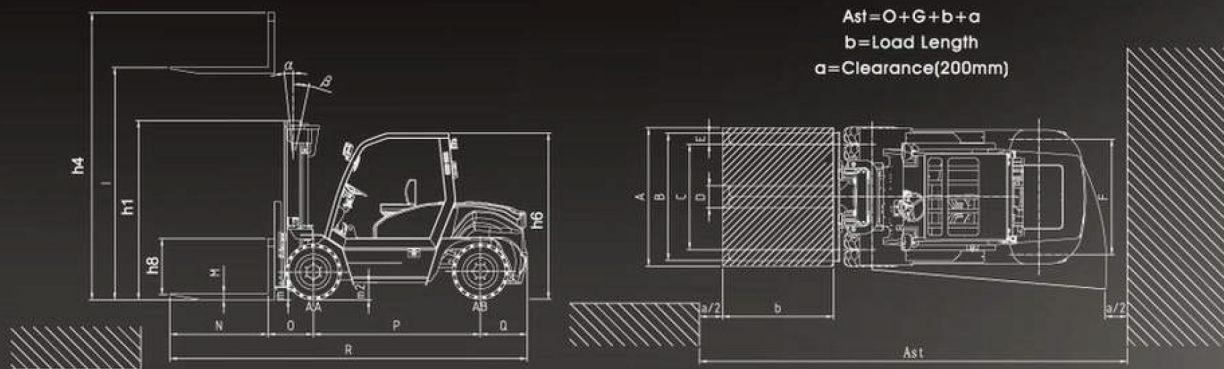

EQUIPMENT AND ACCESSORIES

MANUFACTURER			TAILIFT	TAILIFT	TAILIFT	TAILIFT	
Model			FD60	FD70	FD80	FD100	
Capacity	Q	kg	6000	7000	8000	10000	
Load center	C	mm	600	600	600	600	
Power type			Diesel	Diesel	Diesel	Diesel	
Control type			Sit	Sit	Sit	Sit	
Total width	B	mm	2010	2010	2260	2260	
Height mast lowered	h1	mm	2500	2625	2700	2850	
Height mast extended	h4	mm	4420	4425	4480	4330	
Overhead guard height	h6	mm	2450	2450	2520	2540	
Total length	L2	mm	4755	4815	5410	5625	
Tyres	Number (front/rear)		4/2		4/2		
	Size	Front	AA	8.25-15-14PR	8.25-15-14PR	8.25-20-14PR	9.00-20-14PR
		Rear	AB	8.25-15-14PR	8.25-15-14PR	9.00-16-14PR	9.00-20-14PR
Engine	Model		Perkins	Perkins	Perkins	Perkins	
			1106D	1106D	1106D	1106D	
	Output	Kw	117	118	119	120	
	Speed	rpm	2200	2200	2200	2200	
	No. of Cylinders/displacement	-/c.c.	6/6600	6/6600	6/6600	6/6600	
	Fuel consumption	g/Kw.h	234.9	234.9	234.9	234.9	
Transmission	Type		Hydraulic				
	Manufacturer		OKAMURA			Tailift	

* This is only for your reference and not subject to notice in advance if there is any modification.

FLEXILIFT GROUP HEAD OFFICE

Phone: 1300 55 22 87 Facsimile: 03 9793 6734

Email: info@flexilift.com.au

Web: www.flexilift.com.au

